



# Model : CBGA0042421000-01

## BGA Heat Sink Specification

For 42.5x42.5 Chip set



1. Material : Al 6063

2. Dimension :  
Foot print : 42.5x42.5mm  
Height : 10 mm  
Base (thickness) : 1.7mm

3. Finish : Black Anodize

4. Accessory :  
Clip : Plastic (UL94-V0)  
Thermal pad : 8612I or others

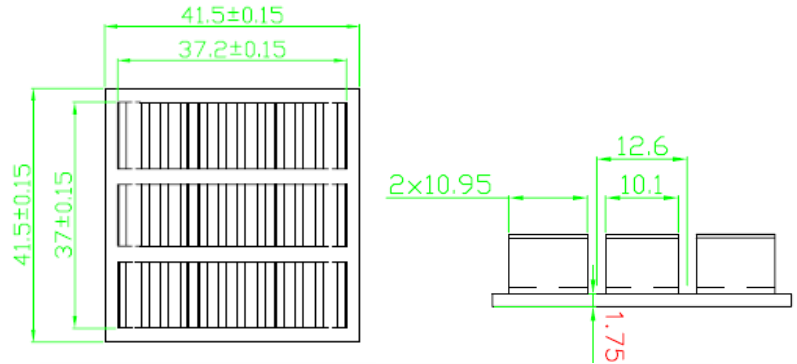

## Performance

Heat Source (LxW)	15x15
-------------------	-------

